

1/4 ROUND SWAGE SPACERS

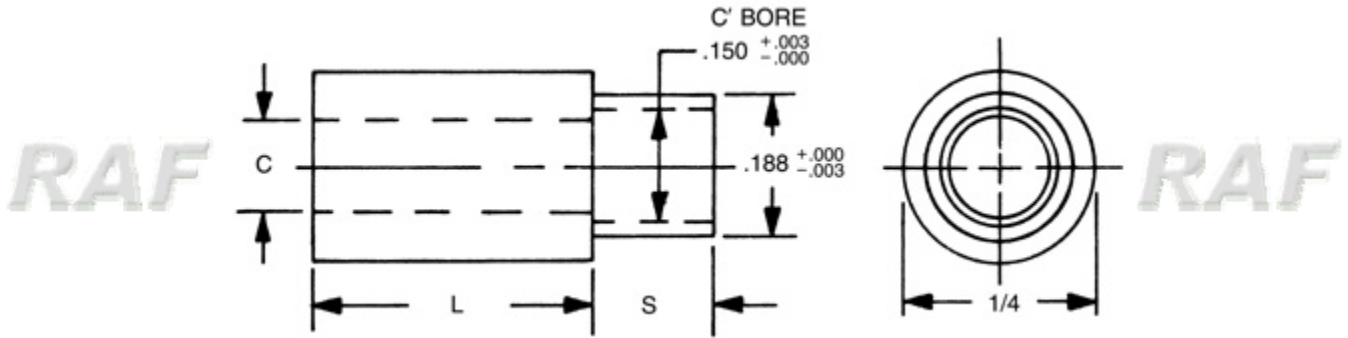

Order Code: 1536-B-6-AL-0

(complete)

Finishes:

Plain Finish

[How to create part numbers](#)

SELECT	PART NO.	LENGTH
<input type="radio"/>	1531A	3/32
<input type="radio"/>	1531	1/8
<input type="radio"/>	1531T	5/32
<input type="radio"/>	1532	3/16
<input type="radio"/>	1532T	7/32
<input type="radio"/>	1533	1/4
<input type="radio"/>	1533T	9/32
<input type="radio"/>	1534	5/16
<input type="radio"/>	1534T	11/32
<input type="radio"/>	1535	3/8
<input type="radio"/>	1535T	13/32
<input checked="" type="radio"/>	1536	7/16
<input type="radio"/>	1536T	15/32
<input type="radio"/>	1537	1/2
<input type="radio"/>	1537T	17/32

SWAGE/PANEL CODE			
Select	S	+ .003 - .003	P
<input type="radio"/>	A	.075	1/32
<input checked="" type="radio"/>	B	.105	1/16
<input type="radio"/>	C	.135	3/32
<input type="radio"/>	D	.165	1/8
<input type="radio"/>	E	.230	3/16
<input type="radio"/>	F	.290	1/4

Select	CODE	MATERIAL	RoHS
<input checked="" type="radio"/>	AL	Aluminum	YES
<input type="radio"/>	B	Brass	YES
<input type="radio"/>	SS	Stainless Steel	YES
<input type="radio"/>	S	Steel	YES

L = SPACER LENGTH
 S = SHANK LENGTH
 P = BOARD THICKNESS
 C = THREAD CLEARANCE HOLE

SWAGE TOOLING		
PUNCH	ANVIL	LENGTH
P-4	AR-22	3/32-3/16
	AR-23	7/32-7/16
	AR-24	15/32-11/16
	AR-25	23/32-1"

Ordering Code				
xxxx	x	x	x	x
Shank		Material		
Length		Clearance Hole		Finish

HOLE CLEARANCE CODE		
Select	CODE	+ .010 - .000
<input type="radio"/>	2	.090
<input type="radio"/>	3	.101
<input type="radio"/>	4	.115
<input checked="" type="radio"/>	6	.140

SELECT	PART NO.	LENGTH
<input type="radio"/>	1538	9/16
<input type="radio"/>	1538T	19/32
<input type="radio"/>	1539	5/8
<input type="radio"/>	1539T	21/32
<input type="radio"/>	1540	11/16
<input type="radio"/>	1540T	23/32
<input type="radio"/>	1541	3/4
<input type="radio"/>	1541T	25/32
<input type="radio"/>	1542	13/16
<input type="radio"/>	1542T	27/32

For non standard items
[please click here](#)

<input type="radio"/>	1543	7/8
<input type="radio"/>	1543T	29/32
<input type="radio"/>	1544	15/16
<input type="radio"/>	1544T	31/32
<input type="radio"/>	1545	1

RAF

© 1999 RAF Electronic Hardware All Rights Reserved
Seymour CT 06483 203 888-2133 Fax: 203 888-9860 www.rafhdwe.com

